

SHRI KALIKA SHEET METAL SOLUTION

## THIN TURRET TOOLING

THICK TURRET  
TRUMPF TYPE  
MURATA TYPE  
SALVAGNINI  
THIN TURRET

# THIN TURRET TOOLING

Drop In Type 5/8" Station (max.Diameter/diagonal 15.8mm)

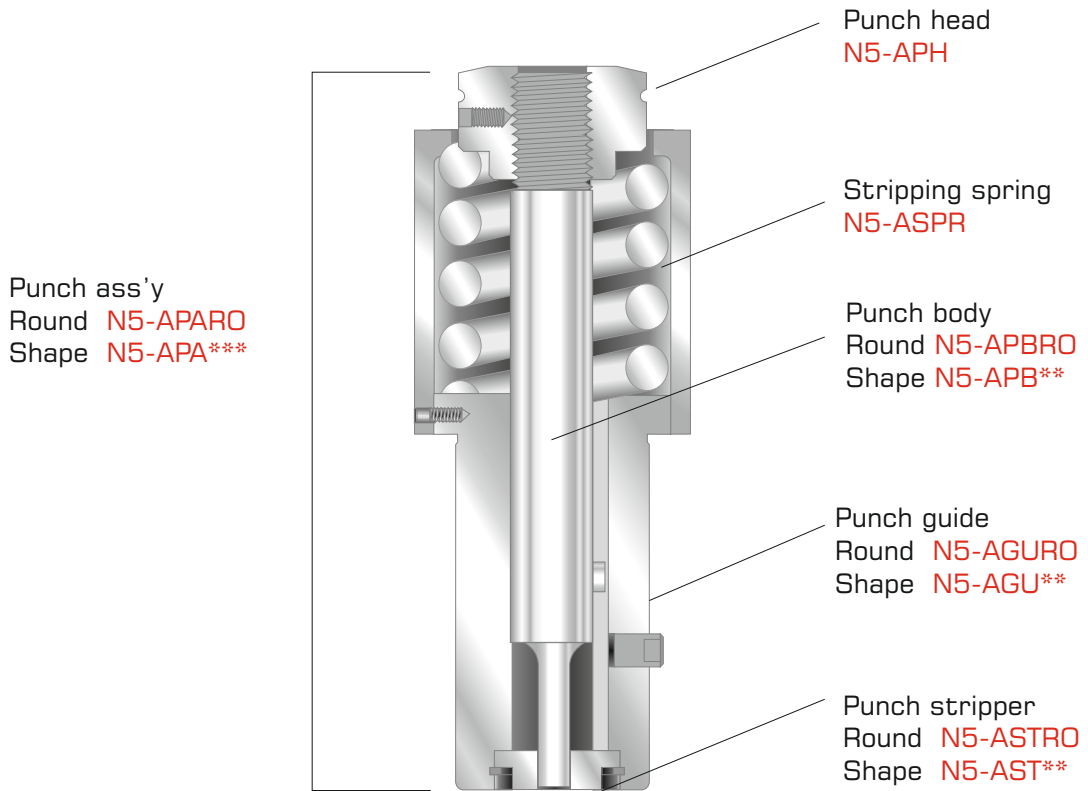

DIE  
Round **N8-BDIRO**  
Shape **N8-BDI\*\***

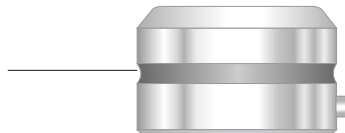

### STANDARD SHAPES

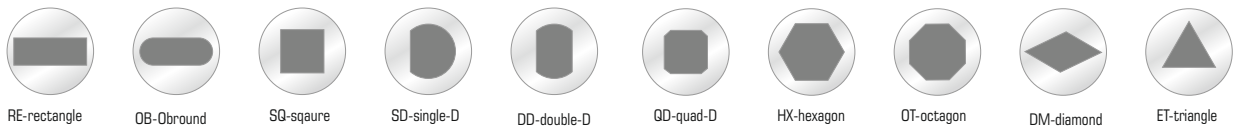

# THIN TURRET TOOLING

S80 Type 1-1/4" Station (max.Diameter/diagonal 31.7mm)

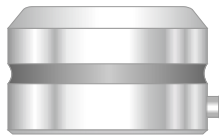
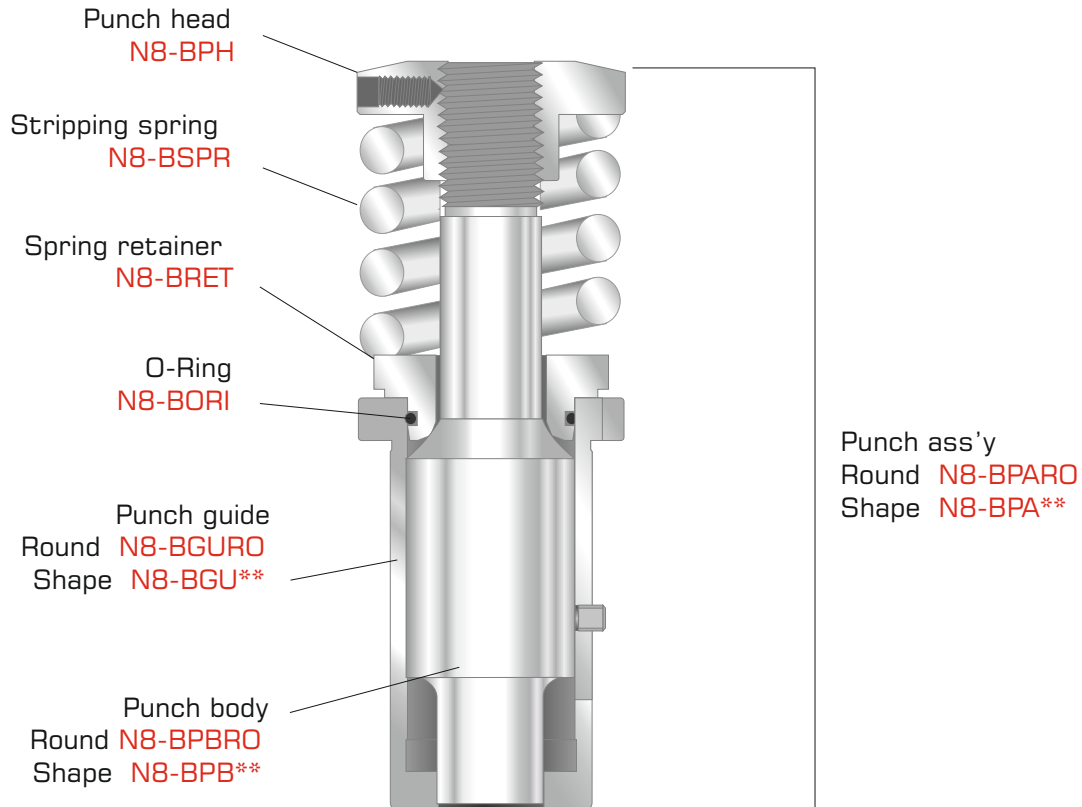

**DIE**  
 Round N8-BDIRO  
 Shape N8-BDI\*\*

## STANDARD SHAPES

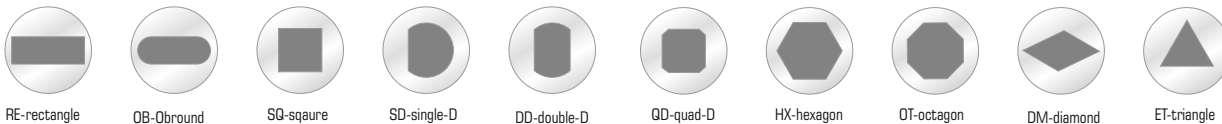

# THIN TURRET TOOLING

S90 Type 1-1/4" Station (max.Diameter/diagonal 31.7mm)

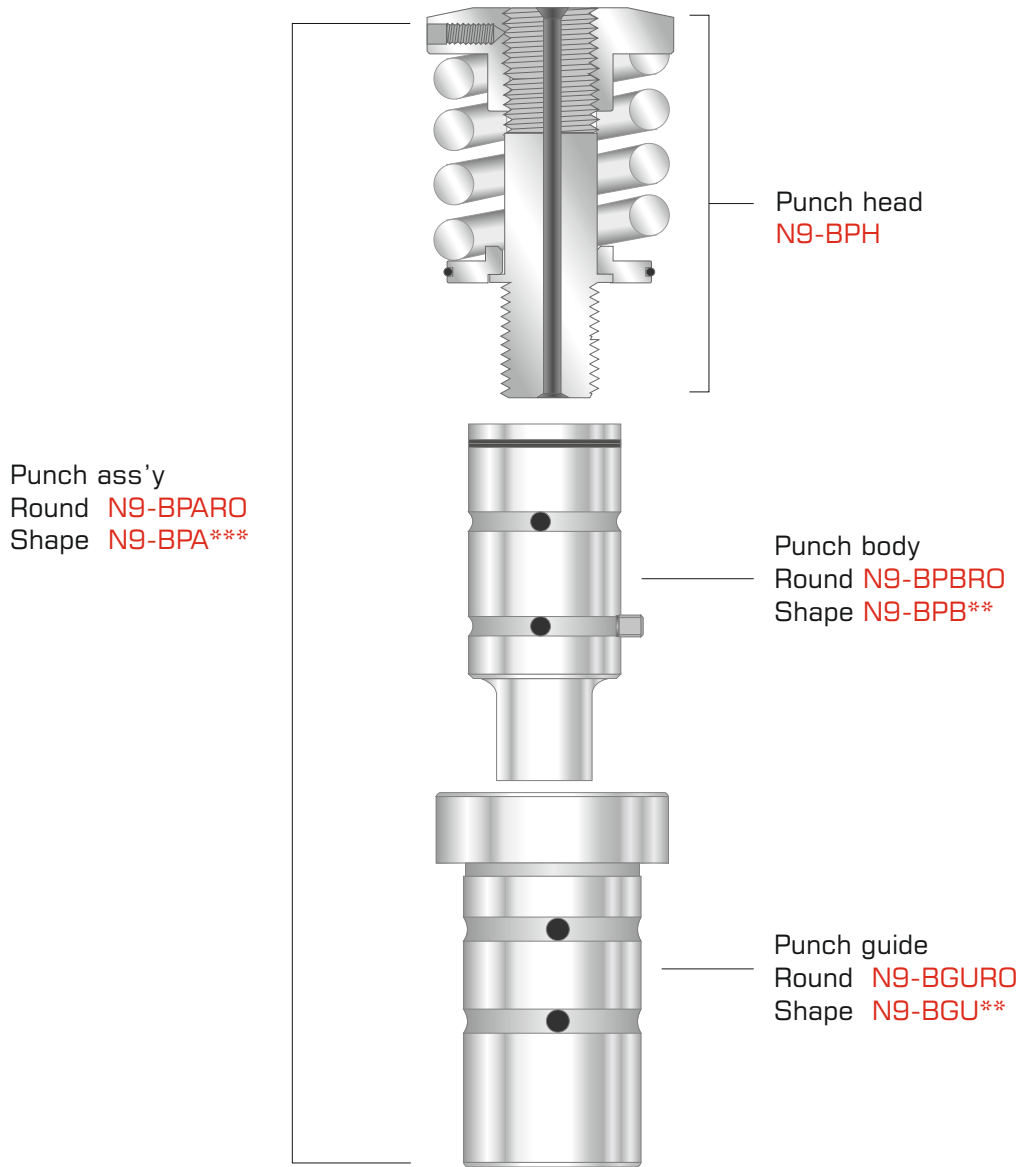

DIE  
Round N8-BDIRO  
Shape N8-BDI\*\*

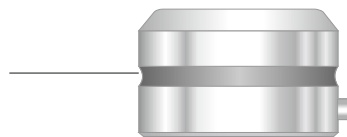

### STANDARD SHAPES

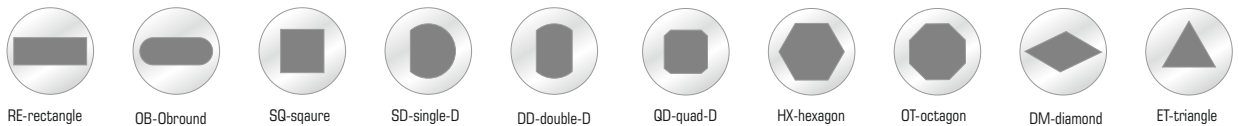

# THIN TURRET TOOLING

3-1/2" STATION (max. S/D Diameter/diagonal 88.9mm)

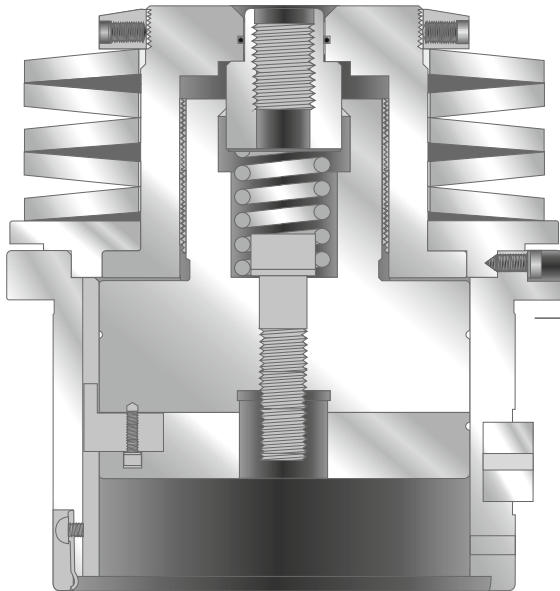

Guide ass'y N9-DGA

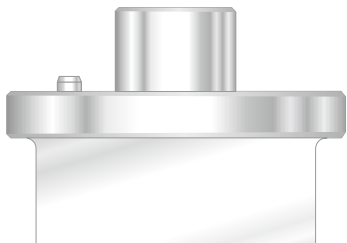

Punch body < 50.8mm  
Round N9-DPB1RO  
Shape N9-DPB1\*\*

Punch body < 88.9mm  
Round N9-DPB1RO  
Shape N9-DPB1\*\*



Stripper  
Round N9-DSTRO  
Shape N9-DST\*\*



Die  
Round N8-DDIRO  
Shape N8-DDI\*\*

## STANDARD SHAPES



RE-rectangle RB-round SQ-square SD-single-D DD-double-D QD-quad-D HX-hexagon OT-octagon DM-diamond ET-triangle



Cad/Cam | Toolings | Accessories

## **ML TECHNOLOGIES**

**Email:** [saipawar@mltechnologies.co.in](mailto:saipawar@mltechnologies.co.in)

[info@mltechnologies.co.in](mailto:info@mltechnologies.co.in)

**Website:** [www.mltechnologies.co.in](http://www.mltechnologies.co.in)